



# Science – Electricity

**Electricity is an energy which can be used to power electrical items.**

## Electrical circuit symbols

When drawing electrical circuits, you should use the standard **symbols** to show the different **components**.

A **circuit** will always have a **cell** or **battery** as well as other **components** connected using wires. Components such as **bulbs**, **buzzers**, **switches** and **motors**, need a battery in order to work.

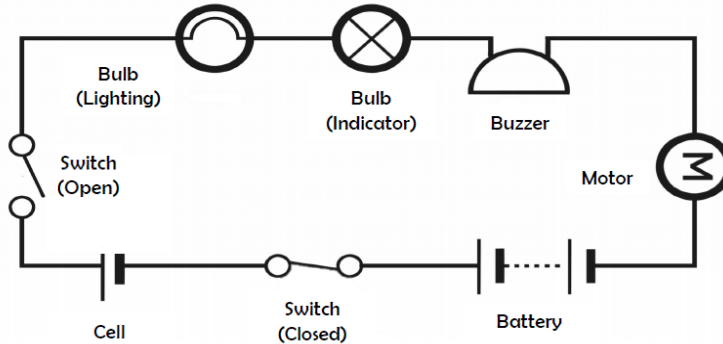

## Variation of components

When **changes** are made to **circuits**, components can function differently.

The **brightness** of a **bulb** or the **loudness** of a **buzzer** is affected by the number of **cells** in a circuit.

When **more bulbs** are added to a circuit, they will be **dimmer** than if there was one bulb. This is because the **electricity** is **shared** between the two bulbs. More voltage would be needed to make them brighter.

When **switches** are **open** or **wires** are **removed** from a circuit (so that it breaks the circuit), bulbs and buzzers will **turn off**.

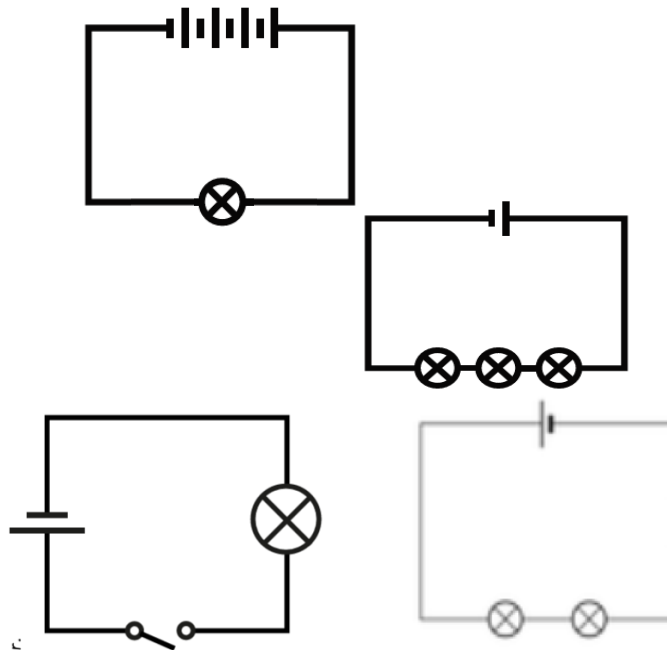

## Key Vocabulary

<b>Circuit</b>	A circuit is a <b>closed loop</b> that an <b>electrical current</b> can flow around.
<b>Symbols</b>	Scientific symbols can be used to represent the components in a circuit. (see diagram)
<b>Insulator</b>	An insulator is an object that <b>does not allow electricity to flow through</b> it easily. Rubber, paper and some plastics are good insulators.
<b>Conductor</b>	A conductor is an object that <b>allows electricity to flow through</b> it easily. Objects made of metal are good conductors.
<b>Component</b>	A part or element used in a circuit. (cell, bulb, buzzer, motor)
<b>Cell</b>	Supplies electrical energy. A cell is a single component.
<b>Battery</b>	A battery is a collection of <b>cells</b> .
<b>Switch</b>	A switch turns an electrical circuit on or off by breaking or completing the circuit
<b>Current</b>	A measure of how much <b>electrical charge</b> flows through a circuit. ( <b>amps</b> )
<b>Voltage</b>	The measure of how much energy is carried by electrical charge; the 'push' from the power source ( <b>volts</b> )

## Scientific Lines of Enquiry

